

Biosensors for Detection of *Francisella Tularensis* and Diagnosis of Tularemia

Petr Skládal, Miroslav Pohanka, Eva Kupská and Bohuslav Šafář
Masaryk University, Brno; Military Technical Institute of Protection, Brno;
Military Academy, Hradec Králové
Czech Republic

1. Introduction

The detection of various types of microbial agents with harmful effects on human population is required in different situations including civil rescue and security units, homeland security, military operations in field, protection of public buildings and transportation systems including airports, metro and railway stations. Such situations need quickly responding, but sufficiently specific detection systems which could be satisfied by portable, rapid and simple instrumentation based on the bioanalytical detection principles (Lim et al., 2005; Gooding, 2006). For bioagents as microbes, viruses and toxins, various types of immunochemical devices seem to be preferred for the early response, good sensitivity and continuous monitoring capabilities. The detection occurs on the phenotype level, thus no extraction of the genetic material from the agent is required, which is the case for methods based on the polymerase chain reaction PCR (Paddle, 1996; Iqbal et al., 2000).

Our efforts in the biodetection area started few years ago; the research on the electrochemical immunosensors for bioagents developed from the previous projects focused on the enzyme-based detection of chemical agents (Krejčí et al., 2008). The principle was amperometric biosensor with immobilized cholinesterase, its inhibition was indication of the presence of target compounds (organophosphate nerve agents) in the surrounding air. From the technological point of view, the biosensor employed thick film based sensors produced by screen-printing; the bioanalytical module was easily exchangeable. The whole device BioNA was small enough (~ 0.5 kg) for hand-held use and it allowed for several hours of continuous operation. The acquired experience was further directed to the development of electrochemical immunosensors for bioagents detection.

The detection of bioagents was originally purely military-oriented task due to the long-lasting historical development of biological warfare agents (BWA). The common classification of bioagents comes from the Centers for Disease Control and Prevention (CDC, www.cdc.gov). BWA are classified in categories A, B and C. The category A contains the most danger agents suitable for easy dissemination and rapid transmission among persons resulting in high mortality; the following microbes are on this list: *Bacillus anthracis*, *Clostridium botulinum* toxin, *Yersinia pestis*, *Variola major*, *Francisella tularensis* and several viruses causing hemorrhagic fevers - Ebola, Marburg and Machupo. The category B includes lower mortality agents moderately easily disseminating, and the category C consists of pathogens that could potentially be engineered for mass dissemination. Overall, some 1400

Source: Biosensors, Book edited by: Pier Andrea Serra,
ISBN 978-953-7619-99-2, pp. 302, February 2010, INTECH, Croatia, downloaded from SCIYO.COM

infectious organisms are pathogenic to humans, including some 200 viral and 500 bacterial species (Taylor et al., 2001). *F. tularensis* was chosen as a model category A microorganism for development and verification of performance of the immunosensor device in our case; this was because this microbe has traditionally been investigated in the Department of Immunology of Military Academy in Hradec Králové for many years (Janovská et al., 2007).

2. Tularemia and *Francisella tularensis*

2.1 Description of the bacterium and the disease

Tularemia belongs to diseases of wild animals as hares, rabbits and rodents; it can be spread by ticks, flies and mosquitoes. The infection can also be obtained from contaminated food, water supply and soil. Occasionally, humans become infected, too. The most frequent disease manifestations are ulceroglandular, glanular, oculoglanular, oropharyngeal, pneumonic, typhoidal and septic, the onset of tularemia is quite fast and symptoms as high fever 38-40 °C, body aches and dry cough can be observed. For disease treatment, antibiotics as streptomycin and gentamicin are widely recommended and tetracycline and chloramphenicol are alternatives (Enderlin et al., 1994).

Francisella tularensis is small and nonmotile gram-negative coccobacillus. As the causative agent of tularemia, it is highly infective and only few microbes aspirated from the surrounding air are able to initiate the disease. For this reason, it was included in the category A of potential biological weapons. *F. tularensis* used to be divided into subtypes A and B. At present, four subspecies are described; the most virulent is the subsp. *tularensis* (subt. A; sometimes also named as *nearctica*, it occurs in the North America and was reported in Europe), *holartica* (subt. B; also referred as *palaeartica*, it is found in the North America as well as in Eurasia), *mediaasiatica* (central Asia) and *novicida* (it was isolated from water supplies in Utah).

2.2 Assay methods

Significant efforts exist towards rapid detection of *Francisella* in various types of samples including air, soil and food. For effective detection in the case of its bioterroristic misuse or for any preventive monitoring, very high sensitivity needs to be achieved, as only few microbes must trigger the positive result. Otherwise, the assay would become inefficient. When cultivation tests are used, the best growth is observed in cysteine-enriched broths and blood or chocolate-supplemented agars. The characteristically opalescent colonies are formed after 24 to 48 hours of incubation at 37 °C in wet atmosphere. A wide range of immunoassays was described including microagglutination (Özcürümez et al., 2004) and ELISA (Schmitt et al., 2005). The PCR is typically focused on the *tul4* and *fopA* genes encoding 17 and 43 kDa outer membrane proteins, respectively (Emanuel et al., 2003). In the case of soil samples, the lowest limit of detection reached only 20 CFU per 1 g of soil (Whitehouse & Hottel, 2006). The real-time PCR based on SYBR Green I and *tul4* gene for *F. tularensis* LVS achieved limit of detection of 0.69 fg of genomic DNA (Sellek et al., 2008). An extensive review of detection methods was published recently (Pohanka et al., 2008).

3. Immunosensing of *Francisella*

For bioanalytical detection of *Francisella*, various types of immunosensors were developed and tested. Generally, immunosensors for microbes employ specific capture of the target

cells in the sensitive area of a suitable transducer followed by formation of an immunocomplex (Fig. 1A). The specific antibodies are mostly prepared against microbial antigens exposed at the cellular surface. Antibodies become immobilized at the sensing surface, and binding of the microbes is followed either directly in real time using piezoelectric and optical devices (Fig. 1A), or indirectly using suitable enzyme labeled secondary antibody and an electrochemical measuring system (Fig. 1B).

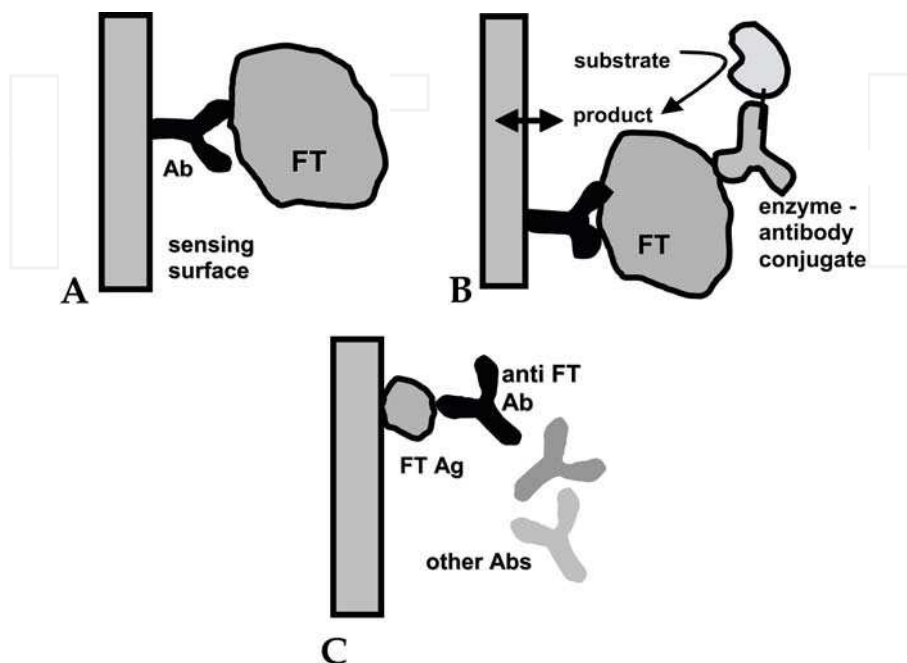

Fig. 1. Schematic view of direct (A) and indirect (B) immunosensors for detection of microbial cells and the direct detection of anti FT antibodies (C). The variants (A, B) employ immobilized capture anti FT antibody, which is specifically binding the target microbe. Alternatively (C), the immobilized FT antigen binds antibodies specific against it. The signal becomes generated in real time for the direct formats (A, C). For the indirect case (B), the captured microbial cell is labeled with the secondary antibody conjugated to a suitable enzyme label. After washing, the bound enzyme converts the added substrate into a measurable product and signal is generated as the last step of the assay.

Properties of the existing immunosensors for detection of *Francisella* are summarized in the following Table 1.

The direct measurement seems very attractive as signal is generated in real time - immediately after addition of the sample, and no additional reagents are required. However, as shown in Table 1, most direct devices provide detection capabilities only for microbial contents above 10^5 CFU/ml; a better sensitivity of assays was demonstrated for some of the indirect devices, where the use of sandwich assay formats with enzyme- or fluorophore-labelled secondary antibodies provides higher specificity and improved detection limits around 10^4 and even 10^3 CFU/ml. On the other hand, these formats employ

additional immunoreagents (Fig. 1B) and also more complex manipulation. The limits of detection required for sufficiently sensitive assay of microbial agents in the form of bioaerosols in air are hard to achieve; a partial improvement can be expected due to the collection systems capturing microbes from the air to the liquid phase (cyclones), though this was not yet demonstrated for *Francisella tularensis*.

Principle / Assay details	LOD (CFU/ml)	Length (min)	Reference
optical bidiffractive grating biosensor / D ID M R	$3 \cdot 10^4$	50	O'Brien et al., 2000
RAPTOR, fiber optic biosensor / ID M R	$1 \cdot 10^5$	10	Anderson et al., 2000
fluorescence immunosensor / ID M R	$5 \cdot 10^5$	15	Taitt et al., 2002
piezoelectric immunosensor / D (IgM clusters)	$5 \cdot 10^6$	35	Pohanka & Skládál, 2005
optical protein chip, sandwich / ID M	$2 \cdot 10^6$	60	Huelseweh et al., 2006
magnetic biosensor, sandwich, freq. mixing / ID, R	$1 \cdot 10^4$	> 60	Meyer et al., 2007
piezoelectric immunosensor / D	$1 \cdot 10^5$	5	Pohanka & Skládál, 2007
electrochemical immunosensor / ID, M	1000	25	Skládál et al., 2006

Table 1. Immunosensors proposed for detection of *Francisella tularensis*. Abbreviations: format D direct, ID indirect (with label), R repeated use, M multianalyte. LOD, limit of detection

4. Immunosensor for detection of tularemia

As it was mentioned above, the detection of cells of *Francisella* is currently not satisfactory compared to the high infectivity, when only few aspirated microbes start the disease. However, the progress of the disease after infection takes few days before clinical symptoms become manifested. Thus, as an alternative to the rather complicated detection of few microbes, an early identification of preclinical symptoms in infected individuals should be considered. In fact, tularemia can be treated with antibiotics effectively if detected shortly after infection. An early detection of the infection in the pre-clinical phase thus can be very valuable for the cases when the detection of microbes fails due to low contents under LOD of the assay. This task should employ measurement of anti-*Francisella* antibodies in serum where these appear during immunological defence of human body against infection.

The immunosensors developed for this purpose in our group will be described in the following text. Again, the formats of such assays can be direct (shown in Fig. 1C) and indirect where the captured anti-*Francisella* antibodies from serum are labeled similarly as in Fig. 1B. For testing of this approach, the mouse model was used (no human samples from individuals suffering with tularemia were available in our country) and the safe live vaccination strain of *Francisella tularensis* LVS was used. As direct and indirect assay formats, piezoelectric and electrochemical immunosensors were developed and tested, respectively.

4.1 Immunization of mice

As an animal model for tularemia, a group of female mice BALB/c was used (specific pathogen free, supplied by BioTest Konárovice, Czech Rep.). Mice were immunized by *F.*

tularensis in order to obtain the immunized mouse serum (IMS); another control group was immunized with *Escherichia coli* to obtain control (CMS) and the last group provided normal serum (NMS) to serve as a blank.

F. tularensis was applied subcutaneously with 10% of the lethal dose LD₅₀ (0.1 ml of solution containing 10⁵ CFU/ml. A similar amount of *E. coli* was inoculated as a negative control. On the days 1, 2, 4, 5, 6, 7, 10, 14 and 21 after immunization, three mice per each group were bled under anesthesia and the collected blood sample was incubated at 37.0 °C for 30 min, the clot was separated and serum was obtained as supernatant after two centrifugations at 3000g for 3 min. Serum samples were stored frozen at -20 °C in aliquots and thawed before measurements. All experiments on animals were realized strictly according to local legislation.

4.2 Direct piezoelectric immunosensor

The piezoelectric quartz crystals with gold electrodes (10 MHz, International Crystal Manufacturing) were modified with a monolayer of cystamine, to which the *F. tularensis* antigen was covalently linked using glutaraldehyde (Pohanka et al., 2007a). The crystal was fixed in a flow-through cell and all assay steps were performed in a flow-through set-up, the solutions at the input were exchanged manually. After stabilization of the initial background frequency (signal) in buffer for 2 to 5 min, the sample was introduced for 5 min to measure its association with the immobilized antigen. Afterwards, a zone of buffer followed and finally, the surface was regenerated for repeated use with 50 mM NaOH with 0.1% Triton X-100. The typical real-time signals for both blank serum and sera from infected mice are shown in Fig. 2, left part, regeneration phase is not shown. The experimental system for measurements with piezoelectric biosensors is presented in Fig. 3.

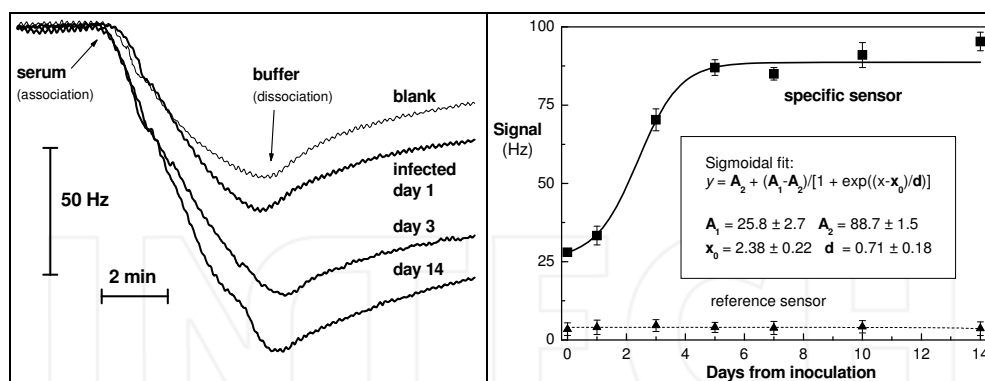

Fig. 2. Progress of infection with *Francisella* in mouse followed using the piezoelectric immunosensor. Levels of anti-*Francisella* antibodies were measured in mouse sera taken in the indicated days after inoculation. Response traces (left) and plot of responses (decrease of frequency as signal) vs. time (right). Specific sensor contained FT antigen covalently linked to the sensing surface, the reference sensor was modified with bovine serum albumin.

The crude non-purified (only diluted 10-times) sera collected from the infected mice on days 1, 3, 5, 7, 10 and 14 after inoculation were measured. NMS from healthy mice and CMS from

mice immunized by *E. coli* served as negative controls. Each sample was diluted ten times. The overall progress of antibody production is presented in Fig. 2, right part. The infection process was obvious even on the 1st day after inoculation; the signal of 33 Hz resulted for IMS while NMS provided only 28 Hz. The rapid increase of response continued to the 5th day (87 Hz) and the further increase was slower achieving maximum at 95 Hz on the 14th day. This behaviour corresponds with the first manifested symptoms of disease around the 5th day from infection (Ohara et al., 1991). No relevant difference between signal of NMS and CMS was observed. The control sensor containing immobilized bovine serum albumin as sensing element provided signals below 5 Hz with all the tested sera - CMS, NMS as well as IMS; this proves specificity of the immunosensor assay.

The obtained results were evaluated using the t-test (IMS vs. NMS, both measured on the specific immunosensor with immobilized LVS antigen, $n = 3$). The results measured on the 1st day after inoculation can be classified as positive with the probability level of 0.95, results from the following days (3rd and higher) were always detected with the probability level of 0.99. The RSD values for the NMS and IMS (day 14) samples were 2.3% and 2.4% for intra-day measurements ($n = 5$).



Fig. 3. The compact piezoelectric immunosensor (left) with integrated flow-through cell. The flow of solutions is realized using the miniperistaltic pump (right). The exchangeable piezoelectric quartz crystal is shown in front.

4.3 Indirect amperometric immunosensor

The amperometric immunosensor was based on the gold screen-printed 4-channel electrode array (AC8, BVT Technologies), *F. tularensis* antigen was covalently immobilized on the self-assembled monolayer of cysteamine (Pohanka & Skládal, 2007b). The serum sample was measured in duplicate together with control and blank; 2.5 μ l of diluted serum was directly dropped on the working electrode and incubated for 5 min. After washing, the anti-mouse peroxidase-labeled tracer Ab (SwAmPx, Sevapharma) was added and incubated for 5 min. Finally, the surface-bound peroxidase was measured amperometrically in a flow-through system:

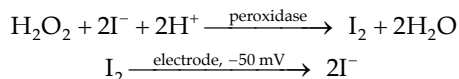

Thus generated signal traces are shown in Fig. 4, left part, for the blank serum (non-infected mouse) and from sera obtained from infected mice taken in the indicated days after infection. The responses of sera (decrease of current) from individual days are shown in the right part together for both *F. tularensis* (immunized) and *E. coli* (control) groups.

The blank signal for NMS varied near around 21 nA without exhibiting any pronounced trend; similar but slightly higher response was observed for the control serum; CMS provided a higher signal (22 to 25 nA) in comparison with NMS. The IMS samples taken one day after immunization demonstrated a signal above 23 nA which was continuously increasing in the following days and resulted in the maximal response of 41 nA 21 days after immunization.

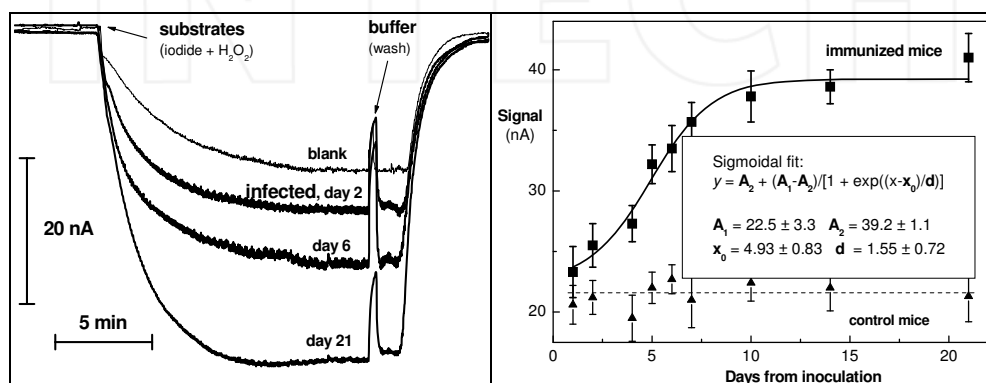

Fig. 4. Progress of infection with *Francisella* in mouse followed using the amperometric immunosensor. Response traces (left) and plot of responses (decrease of current as signal) vs. time (right). Specific sensor contained FT antigen covalently linked to the sensing surface, sera from non-immunized mice served as control.

Significantly higher signals from IMS were measured on the 5th day after immunization (32.2 ± 1.6 nA) in comparison with CMS (25.0 ± 1.9 nA). Statistically, distinguishing IMS and CMS in one day after immunization was questionable; the probability of difference was on the level 0.60 (t-test). In the following sampling on days 2 and 4, the probability grew up to the levels 0.75 and 0.89, respectively, and starting on the 5th day, the probability level was above 0.99.

The developed amperometric immunosensor provided good reliability and sensitivity of assays. A small amount of 2.5 μl sample was based on appropriately diluted 0.1 μl of original sera. Consequently, this technique can be applied in field laboratories. The instrumentation used for measurements (Fig. 5) is fully portable and battery operated (> 10 hours after full charge). After insertion of the strip sensor to the cell, the measuring sequence is fully automated using a script-based programming. The flow-through format was adopted due to better precision of assays; if the measurement will be based on a drop of substrate mixture, further miniaturization can be feasible. An important parameter of the assay is the speed of measurement. Here, the limiting step was measurement of the output signal (5 min). The other assay steps such as preincubation with sample and regeneration

can be parallelized and include unlimited number of biosensors. Thus, considering four measuring spots per the strip, up to ten measuring cycles corresponding to 40 assays can be realized within one hour.

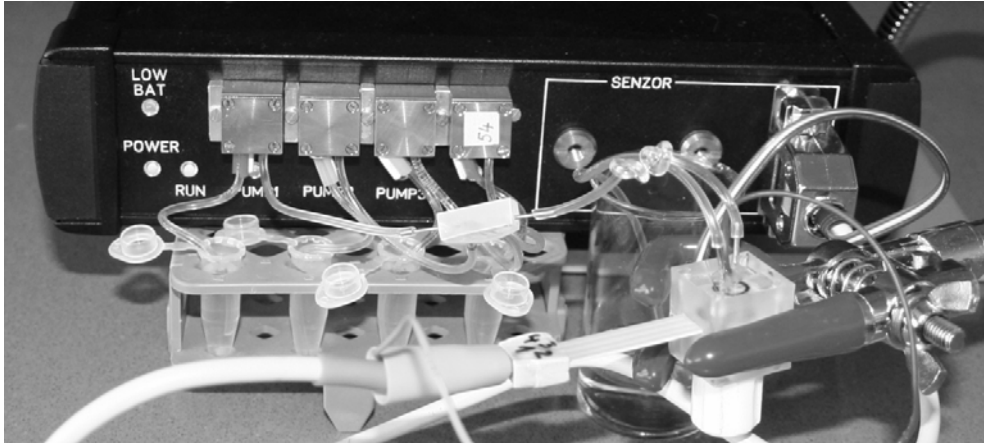

Fig. 5. The amperometric immunosensor detector ImmunoSMART. In the left part of the front panel, four miniature peristaltic pumps are connected to minitubes with bioreagents. The flow-through cell fixed in the holder contains the exchangeable screen-printed immunosensor.

4.4 Correlation of results from piezoelectric and amperometric immunosensors

To compare evaluation of sera originated from infected mice, the results obtained from both piezoelectric and amperometric immunosensors were plotted in Fig. 6. For a straightforward

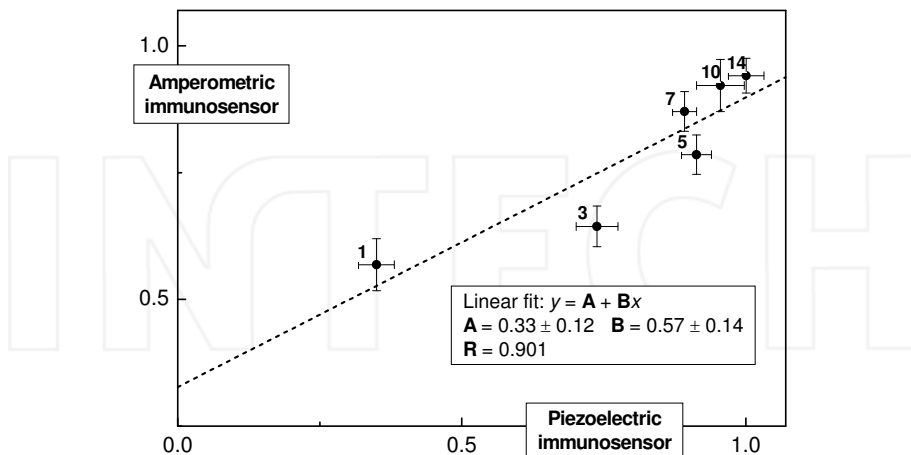

Fig. 6. Correlation of results for detection of anti FT antibodies in immunized mouse sera between piezoelectric and amperometric immunosensor; normalized data were used for correlation.

comparison, data from both systems were normalized; the results were divided by the maximal observed response to be within the 0 to 1 range. A linear correlation was obtained ($R = 0.901$), however, the slope of the linear regression was not equal to 1 as well as the intercept value was significantly different from 0. Obviously, this is due to the higher proportion of the binding fraction of serum immunoglobulins able to recognize a wider group of microbial antigens even before the infection with *F. tularensis* took place; this was affecting response of the amperometric immunosensor significantly more than the piezoelectric one. In fact, the simplified assay procedure for the latter one seems advantageous, as there can not be any influence of the tracer binding. In addition, based on the statistical t-test data, the direct piezoelectric system allowed earlier to resolve the sera originating from control and infected mice.

5. Future trends

Despite the promising results allowing rather fast identification of infection with tularemia, the straightforward detection and identification of bioagents remains challenging.

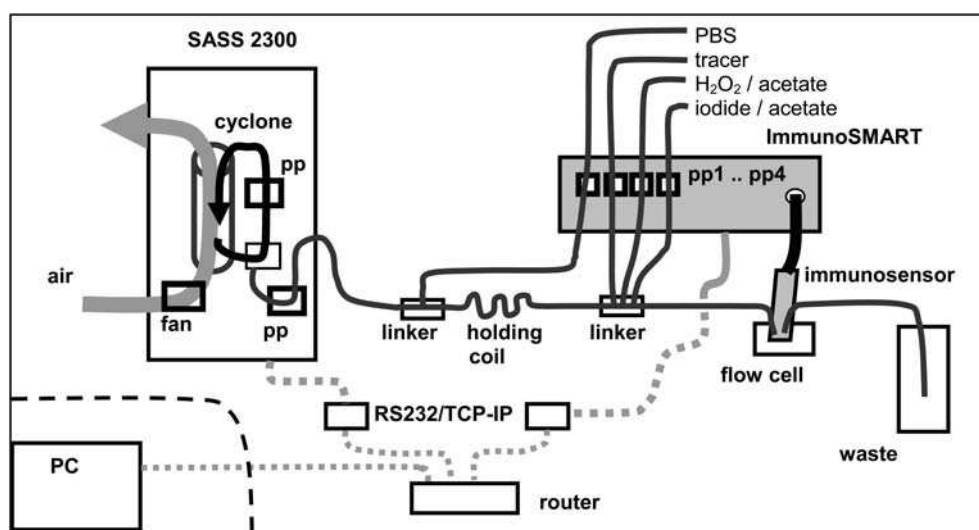

Fig. 7. Schematic representation of an amperometric immunosensor linked to the cyclone device for detection of bioaerosols.

In real situations, the monitoring of air for presence of danger bioagents should be carried out with sufficiently low limits of detection. For this reason, sampling of the monitored air should be realized with the help of a cyclone system, which captures particles from air and concentrates them in a small volume of solution. Thus obtained sample can be subsequently analyzed with either direct or indirect immunosensor (Fig. 7). For detection of bioagents, the amperometric detector should be preferred, as the use of enzyme labels provides significantly enhanced sensitivity compared to direct protocols (Table 1). The system based on the developed immunosensor detector ImmunoSMART and a commercially available cyclone SASS 2300 (Research International) is shown in Fig. 8. A program controlling both subsystems was developed in order to allow synchronized operation.

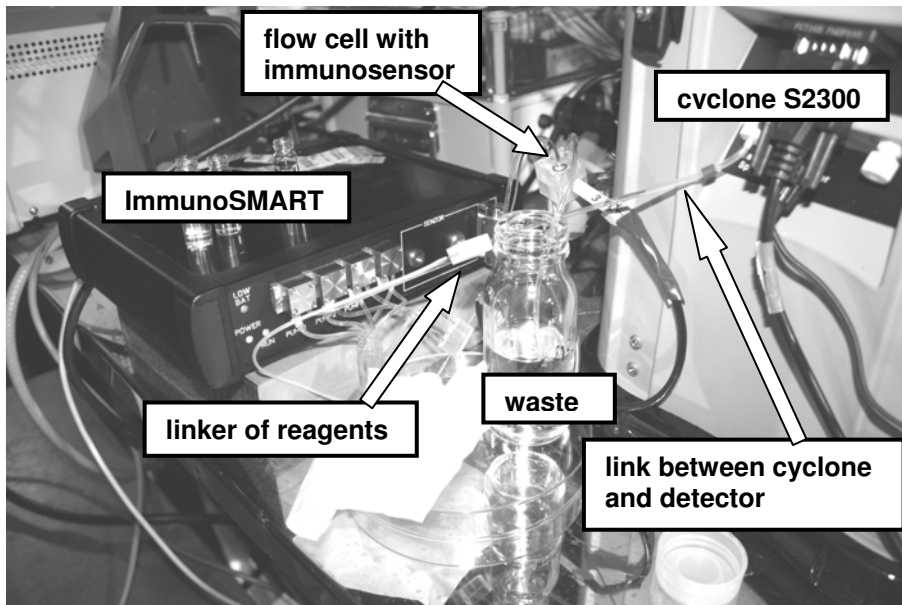

Fig. 8. Set-up for analysis of bioaerosols consisting of the detector ImmunoSMART and cyclone SASS 2300 (Research International).

For model detection of microbes in bioaerosols, the completely safe strain of *Escherichia coli* DH5 α was used as *Francisella* must not be disseminated in air. In this case, sampling of air was carried out using a cyclone device for 10 min and the accumulated sample was transferred to the ImmunoSMART device. Preliminary unpublished results indicate feasibility of detection of 100 CFU/l in air, the total time of analysis being around 20 min.

6. Conclusion

The amperometric and piezoelectric immunosensors suitable for assay of *Francisella tularensis* and the associated disease tularemia are developed. A novel method for the indirect detection was based on the measurement of anti tularemic antibodies in serum samples of infected mice as a model microorganism. The direct piezoelectric biosensor was able to detect the onset of the infection process very early, even one day after injection of the bioagent. The advantage of this method is a simple direct arrangement with low cost of analysis. The proposed concept of the immunosensor seems to be suitable also for screening of human sera. The current efforts are mainly focused on the direct detection of harmful bioagents as bacteria, viruses, toxins and other pathogen and biosensors play quite important role. However, for the highly toxic bioagents causing infection in only a very small dose (low concentration, few microorganisms only), the primary detection could potentially fail and the bioagents will remain undetected. In this case, the highly sensitive complementary detection of the infection becomes extremely important. In addition, a novel method for the indirect detection of *Francisella tularensis* was based on the screen-printed electrochemical sensing array with four measuring spots. The advantage of this multichannel sensor is the option for simultaneous measurement of the tested sample and

the control negative blank. In this way, the acquired responses will allow compensation of fluctuations in assay conditions (temperature, flow rate stability, decrease of the binding capacity, etc.). This becomes quite important when the developed immunosensor becomes utilized in field conditions.

7. References

- Anderson, G.P.; King, K.D.; Gaffney, K.L. & Johnson, L.H. (2000) Multi-analyte interrogation using the fiber optic biosensor. *Biosens. Bioelectron.* 14, 10-11 (Nov. 2000) 771-777, 0956-5663
- Emanuel, P.A.; Dang, J.; Gebhardt, J.S.; Aldrich, J.; Garber, E.A.E.; Henrieta, K.; Stopa, P.; Valdes, J.J. & Schultz, A.D. (2000). Recombinant antibodies: a new reagent for biological agent detection. *Biosens. Bioelectron.* 14, 10-11, (Nov. 2000) 761-770, 0956-5663
- Enderlin, G.; Morales, L.; Jacobs, R.F. & Cross, J.T. (1994). Streptomycin and alternative agents for the treatment of tularemia: review of the literature. *Clin. Infect. Dis.* 19, 1 (July 1994) 42-47, 1058-4838
- Gooding, J.J. (2006). Biosensor technology for detecting biological warfare agents: Recent progress and future trends. *Anal. Chim. Acta* 559, 2 (Feb. 2006) 137-151, 0003-2670
- Huelseweh, B.; Ehrlich, R. & Marschall, H.J. (2006) A simple and rapid protein array based method for the simultaneous detection of biowarfare agents. *Proteomics* 6, 10 (May 2006) 2972-2981, 1615-9853
- Iqbal, S.S.; Mayo, M.W.; Bruno, J.G.; Bronk, B.V.; Batt, C.A. & Chambers, J.P. (2000). A review of molecular recognition technologies for detection of biological threat agents, *Biosens. Bioelectron.* 15, 11 (Dec. 2000), 549-578, 0956-5663
- Janovská, S.; Pávková, I.; Hubálek, M.; Lenco, J.; Macela, A. & Stulík, J. (2007). Identification of immunoreactive antigens in membrane proteins enriched fraction from *Francisella tularensis* LVS. *Immunol. Lett.* 108, 2 (Feb. 2007) 151-159, 0165-2478
- Krejčí, J.; Grosmanová, Z.; Krejčová, D.; Skládal, P. & Šafář, B. (2008). Biosensor Detection of Organophosphorous Gases, In: *Commercial and Pre-Commercial Cell Detection Technologies for Defence against Bioterror - Technology, Market and Society, NATO Science for Peace and Security Series - E: Human and Societal Dynamics, Vol. 39*, Lechuga, L.M.; Milanovich, F.P.; Skládal, P.; Ignatov, O. & Austin, T.R. (Ed.) 155-165, IOS Press, 978-1-58603-858-8, Amsterdam, The Netherlands
- Lim, D.V.; Simpson, J.M.; Kearns, E.A. & Kramer, M.F. (2005). Current and developing technologies for monitoring agents of bioterrorism and biowarfare. *Clin. Microbiol. Revs.* 18, 4 (Oct. 2005) 583-607, 0893-8512
- Meyer, M.H.F.; Krause, H.J.; Hartmann, M.; Miethe, P.; Oster, J. & Keusgen, M. (2007) *Francisella tularensis* detection using magnetic labels and a magnetic biosensor based on frequency mixing. *J. Magnetism Magnet. Mat.* 311, 1 (Apr. 2007) 259-263, 0304-8853
- O'Brien, T.; Johnson, L.H.; Aldrich, J.L.; Allen, S.G.; Liang, L.T.; Plummer, A.L.; Krak, S.J. & Boiarski, A.A. (2000) The development of immunoassays to four biological threat agents in a bidiffractive grating biosensor. *Biosens. Bioelectron.* 14, 10-11 (Nov. 2000) 815-828, 0956-5663

- Ohara, T.; Sato, H.; Fujita, T.; Ueno, M. & Homma, M. (1991) Clinical manifestation of tularemia in Japan - analysis of 1355 cases observed between 1924 and 1987. *Infection* 19, 1 (Jan. 1991) 14-17, 0300-8126
- Özcürümez, M.P.; Kischel, N.; Priebe, H.; Spletstößer, W.; Finke, E.J. & Grunow, R. (2004). Comparison of enzyme-linked immunosorbent assay, western blotting, microagglutination, indirect immunofluorescence assay, and flow cytometry for serological diagnosis of tularemia. *Clin. Diagn. Lab. Immunol.* 11, 6 (Nov. 2004) 1008-1015, 1098-6588
- Paddle, B.M. (1996). Biosensors for chemical and biological agents of defence interest. *Biosens. Bioelectron.* 11, 11 (Nov. 1996), 1079-1113, 0956-5663
- Pohanka, M. & Skládal, P. (2005) Piezoelectric immunosensor for *Francisella tularensis* detection using immunoglobulin M in a limiting dilution. *Anal. Lett.* 38, 3 (March 2005) 411-422, 0003-2719
- Pohanka, M. & Skládal, P. (2007a) Piezoelectric immunosensor for the direct and rapid detection of *Francisella tularensis*. *Folia Microbiol.* 52,4 (Feb. 2007) 325-330, 0015-5632
- Pohanka, M. & Skládal, P. (2007b) Serological diagnosis of tularemia in mice using the amperometric immunosensor. *Electroanalysis* 19,24 (Dec. 2007) 2507-2512, 1040-03971040-0397
- Pohanka, M.; Pavliš, O. & Skládal, P. (2007) Diagnosis of tularemia using piezoelectric biosensor technology. *Talanta* 71,2 (Feb. 2007) 981-985, 0039-9140
- Pohanka, M.; Hubálek, M.; Neubauerová, V., Macela, A.; Faldyna, M.; Bandouchová, H. & Pikula, J. (2008). Current and emerging assays for *Francisella tularensis* detection: a review. *Veterinarni Medicina* 53, 11 (Nov. 2008) 585-594, 0375-8427
- Schmitt, P.; Spletstößer, W.; Özcürümez, M.P.; Finke, E.J. & Grunow, R. (2005). A novel screening ELISA and a confirmatory western blot useful for diagnosis and epidemiological studies of tularemia. *Epidemiol. Infect.* 133, 4 (Aug. 2005) 759-766, 1469-4409
- Sellek, R., Jimenez, O.; Aizpurua, C.; Fernandez-Frutos, B.; De Leon, B.; Camanacho, M.; Fernandez-Moreira, D.; Ybarra, C. & Carlos Cabria, J. (2008). Recovery of *Francisella tularensis* from soil samples by filtration and detection by real-time PCR and cELISA. *J. Environ. Monit.* 10, 3 (Mar. 2008) 362-369, 1464-0325
- Skládal, P.; Symerská, Y.; Pohanka, M.; Šafář, B. & Macela, M. (2005) Electrochemical immunosensor for detection of *Francisella tularensis*, In: *Defence against Bioterror: Detection Technologies, Implementation, Strategies and Commercial Opportunities*, NATO Security through Science Ser. B - Physics and Biophysics, Morrison, D; Milanovich, F.; Ivnitiski, D. & Austin, T.R. (Ed.) 221-232, Springer, 1-4020-3386-9, Dordrecht, The Netherlands
- Taitt, C.R.; Anderson, G.P.; Lingerfelt, B.M.; Feldstein, M.J. & Ligler, F.S. (2002) Nine-analyte detection using an array-based biosensor. *Biosens. Bioelectron.* 17, 23 (Dec. 2002) 6114-6120, 0956-5663
- Taylor, L.H.; Latham, S.M. & Woolhouse, M.E.J. (2001). Risk factors for human disease emergence. *Phil. Trans. R. Soc. Lond. B* 356, 1411 (July 2001) 983-989 1471-2970
- Whitehouse, C.A. & Hottelm H.E. (2006). Comparison of five commercial DNA extraction kits for the recovery of *Francisella tularensis* DNA from spiked soil samples. *Mol. Cell Probes* 21, 2 (Apr. 2006) 92-96, 1096-1194



Biosensors

Edited by Pier Andrea Serra

ISBN 978-953-7619-99-2

Hard cover, 302 pages

Publisher InTech

Published online 01, February, 2010

Published in print edition February, 2010

A biosensor is defined as a detecting device that combines a transducer with a biologically sensitive and selective component. When a specific target molecule interacts with the biological component, a signal is produced, at transducer level, proportional to the concentration of the substance. Therefore biosensors can measure compounds present in the environment, chemical processes, food and human body at low cost if compared with traditional analytical techniques. Bringing together researchers from 11 different countries, this book covers a wide range of aspects and issues related to biosensor technology, such as biosensor applications in the fields of drug discovery, diagnostics and bacteria detection, optical biosensors, biotelemetry and algorithms applied to biosensing.

How to reference

In order to correctly reference this scholarly work, feel free to copy and paste the following:

Petr Skládal, Miroslav Pohanka, Eva Kupská and Bohuslav Šafář (2010). Biosensors for Detection of Francisella Tularensis and Diagnosis of Tularemia, Biosensors, Pier Andrea Serra (Ed.), ISBN: 978-953-7619-99-2, InTech, Available from: <http://www.intechopen.com/books/biosensors/biosensors-for-detection-of-francisella-tularensis-and-diagnosis-of-tularemia>

INTECH
open science | open minds

InTech Europe

University Campus STeP Ri
Slavka Krautzeka 83/A
51000 Rijeka, Croatia
Phone: +385 (51) 770 447
Fax: +385 (51) 686 166
www.intechopen.com

InTech China

Unit 405, Office Block, Hotel Equatorial Shanghai
No.65, Yan An Road (West), Shanghai, 200040, China
中国上海市延安西路65号上海国际贵都大饭店办公楼405单元
Phone: +86-21-62489820
Fax: +86-21-62489821